

MACTECH

MD414 MAGNETIC DRILL

MACTECHONSITE.COM

PRODUCT DESCRIPTION

Mactech's MD414 Magnetic Drill is a versatile and easy to use tool for on-site drilling. The MD414 is ideally suited for applications where quick set-up and powerful drilling is required. Utilizing its magnetic base allows the MD414 to be easily attached to almost any ferrous surface. An optional Hanger Bracket allows the drill to be positioned at a set distance from the top of a pipe or other structure. While a set of Welding Brackets are also available to meet the most complex drilling scenarios. Available with five different motor packages and a variety of arbors and tool holders, the MD414 Magnetic Drill is ready for the demands of your job.

FEATURES

- **QUICK MAGNETIC ATTACHMENT FOR EASY SETUP**
- **PORTABLE COMPACT DESIGN**
- **POWERFUL AIR, HYDRAULIC OR ELECTRIC MOTORS**

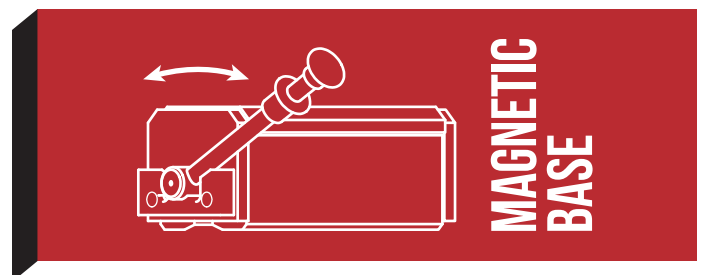

MACTECH INC.
4079 PEPIN AVE UNIT 4
RED WING MN 55066
800-328-1488
INFO@MACTECHONSITE.COM

MACTECH OFFSHORE
302 IDA ROAD
BROUSSARD LA 70518
337-839-2793
INFO@MACTECHOFFSHORE.COM

MACTECH KENTUCKY
3880 INDUSTRIAL DRIVE
PADUCAH KY 42001
270-442-1559
INFO@MACTECHONSITE.COM

MACTECH WISCONSIN
2515 CLEVELAND AVE
MARINETTE WI 54143
800-328-1488
INFO@MACTECHONSITE.COM

MACTECH INTERNATIONAL
CONTACT US FROM ANYWHERE
AROUND THE WORLD
800-328-1488
INFO@MACTECHONSITE.COM

WORK HARD

WORK SAFE

WE BEFORE ME

WELCOME CHALLENGES

WOW THEM

MACTECH

MD414 MAGNETIC DRILL

MACTECHONSITE.COM

AVAILABLE DRIVES

DRIVES	POWER	SPINDLE SPEED	TORQUE
AIR DRIVE: IN-LINE, REVERSIBLE			
* 605-6857	1.6 HP / 1200w	107rpm @ Max Power, 227rpm Free Speed	85FtLbs / 115 Nm @ Max Power
AIR DRIVE: RIGHT ANGLE, REVERSIBLE			
* 605-6858	1.6 HP / 1200w	107rpm @ Max Power, 227rpm Free Speed	85FtLbs / 115 Nm @ Max Power
HYDRAULIC DRIVE: IN-LINE			
600-6769	3.4 HP @ 8 GPM/1000psi	127rpm - 913rpm, 500rpm @ 8gpm	35 ft-lbs @ 1000psi, 66FtLbs @ 1800psi
ELECTRIC DRIVE: 20 AMP, 110VAC REVERSIBLE			
600-6855	3hp	4 Speed Gearbox / 80-570rpm, w/ Speed Dial	203 ft-lbs / 276 Nm @ 80rpm
ELECTRIC DRIVE: 10 AMP, 220VAC REVERSIBLE			
600-6856	3hp	4 Speed Gearbox / 80-570rpm, w/ Speed Dial	203 ft-lbs / 276 Nm @ 80rpm

* Air motors require 74 cfm @ 87 psi air supply (2.1 m³/min @ 6 bar)

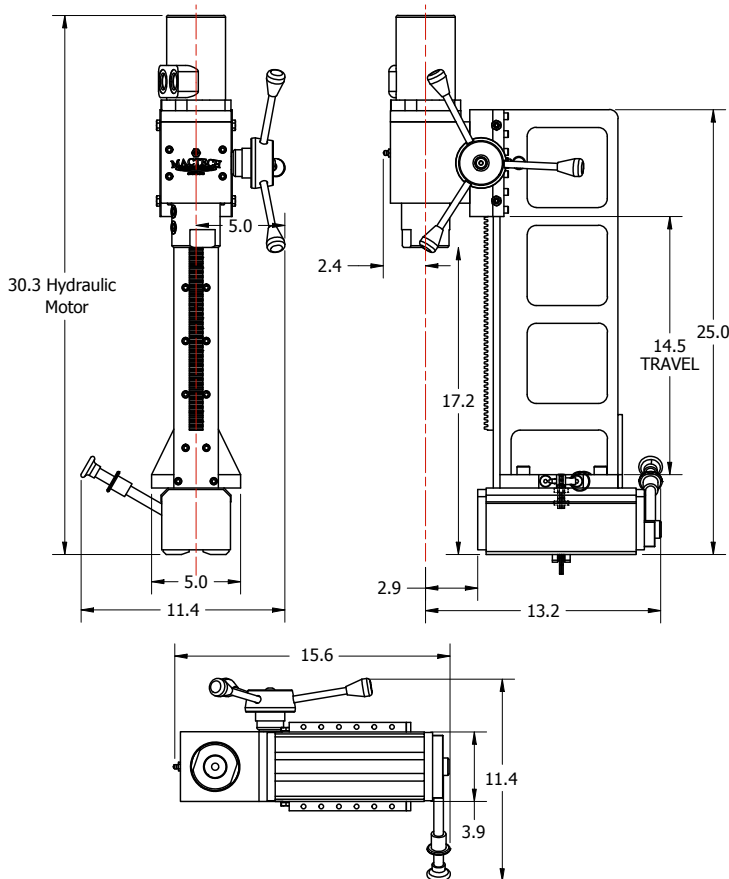

MD414 DIMENSIONS

	HEIGHT	WEIGHT
Drill Base	25in / 63.5cm	81.45 lbs / 37kg
HEIGHT & WEIGHT WITH DRIVE		
DRIVE	HEIGHT	WEIGHT
Air Drive: In-line	40.5in / 1m	101.5 lbs / 46kg
Air Drive: RA	31in / 78.7cm	101.5 lbs / 46kg
Hydraulic Drive	30.3in / 77cm	93 lbs / 42kg
Electric Drives	43.6in / 1.1m	103.5 lbs / 47kg

ARBOR:

- 1.25in / 31.75mm straight quill
- Other arbors and tool holders are available.

DRILL CAPACITY:

- 1.5in / 38.1mm twist drill
- 3in / 76.2mm annular cutter

MAGNETIC ATTACHMENT BASE

- Max load, flat surface: 1100 lbs. (499 kg)
- Max load, round surface: 550 lbs. (249 kg)
- Detachment force: 3575 lbs. (1622 kg)

All dimensions are for reference and may be subject to change without notice. Machine performance is subject to application and operator capability; please discuss your requirements directly with a Mactech sales representative. All information given and all sales made by Mactech Inc. are subject to their terms and conditions.

WORK HARD

WORK SAFE

WE BEFORE ME

WELCOME CHALLENGES

WOW THEM