

MACTECH

BB 6000 6" BORING BAR SYSTEM

MACTECHONSITE.COM

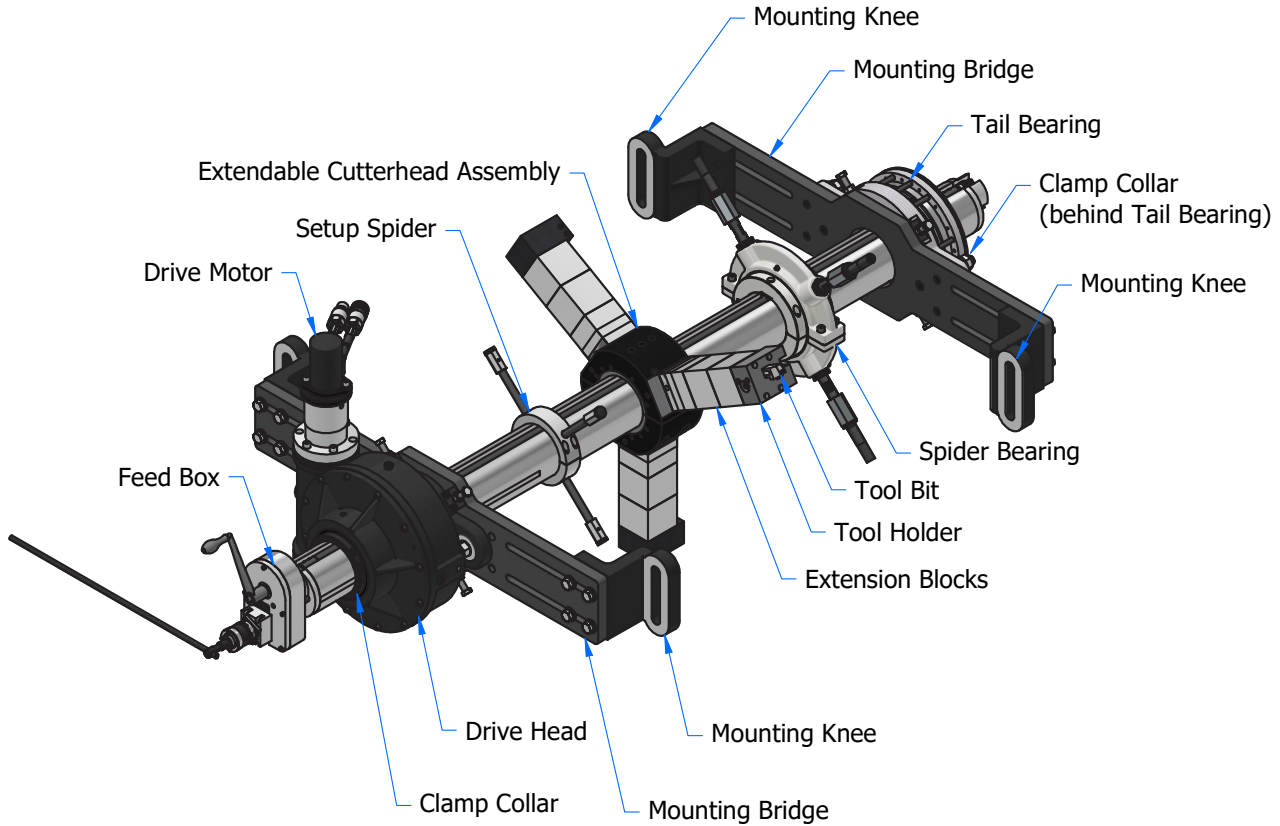

PRODUCT DESCRIPTION

Mactech's simple to operate BB6000 Boring Bar is the solution for any bore repair that needs to be done right away. Powerful, accurate machining gets your equipment up and running fast, reducing your downtime and saving you money. The BB6000 system can utilize Hydraulic or Electric drive motors. Custom setups are our specialty, give us a call and we will make a system suited just for your application.

Contact Mactech about our Facing Arm options!

All dimensions and hydraulic requirements are for reference and may be subject to change without notice. Machine performance is subject to application and operator capability; please discuss your requirements directly with a Mactech sales representative. All information given and all sales made by Mactech Inc. are subject to their terms and conditions.

SPECIFICATIONS

Cutting Capacity	12" - 48" Inches
	305mm - 1219mm
Cutting Capacity (with Extension Kit)	48" - 72" Inches
	1219mm - 1829mm
Tooling	1" Sq. Shank
Axial Feed Rate	.003" / .004" / .006" Rev.
	0.08 / 0.11 / 0.16mm Rev.
Drive Head Gear Ratio	45:1
Hydraulic Motor RPM	16 bar RPM at 12 GPM
Electric Drive RPM	37 bar RPM Max
Bar Length	Variable: Contact Mactech with desired length

MACTECH INC.
4079 PEPIN AVE UNIT 4
RED WING MN 55066
800-328-1488
INFO@MACTECHONSITE.COM

MACTECH OFFSHORE
302 IDA ROAD
BROSSARD LA 70518
337-839-2793
INFO@MACTECHOFFSHORE.COM

MACTECH KENTUCKY
3880 INDUSTRIAL DRIVE
PADUCAH KY 42001
270-442-1559
INFO@MACTECHONSITE.COM

MACTECH WISCONSIN
2515 CLEVELAND AVE
MARINETTE WI 54143
800-328-1488
INFO@MACTECHONSITE.COM

MACTECH INTERNATIONAL
CONTACT US FROM ANYWHERE
AROUND THE WORLD
337-839-2793
INFO@MACTECHOFFSHORE.COM

WORK HARD

WORK SAFE

WE BEFORE ME

WELCOME CHALLENGES

WOW THEM

MOUNTING BRIDGE DIMENSIONS

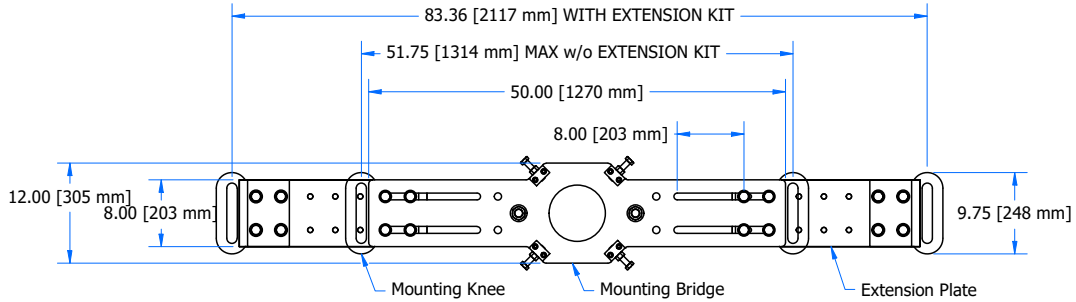

CUTTING RANGE

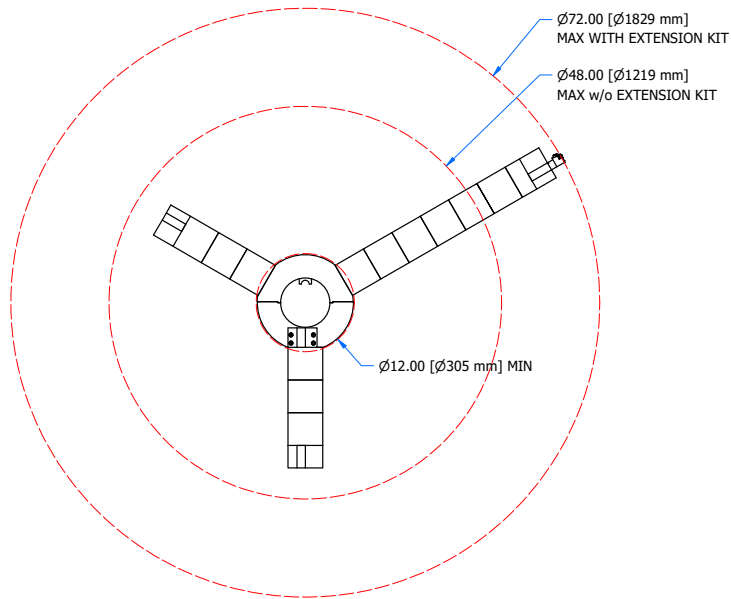

COMPONENT SETUP DIMENSIONS

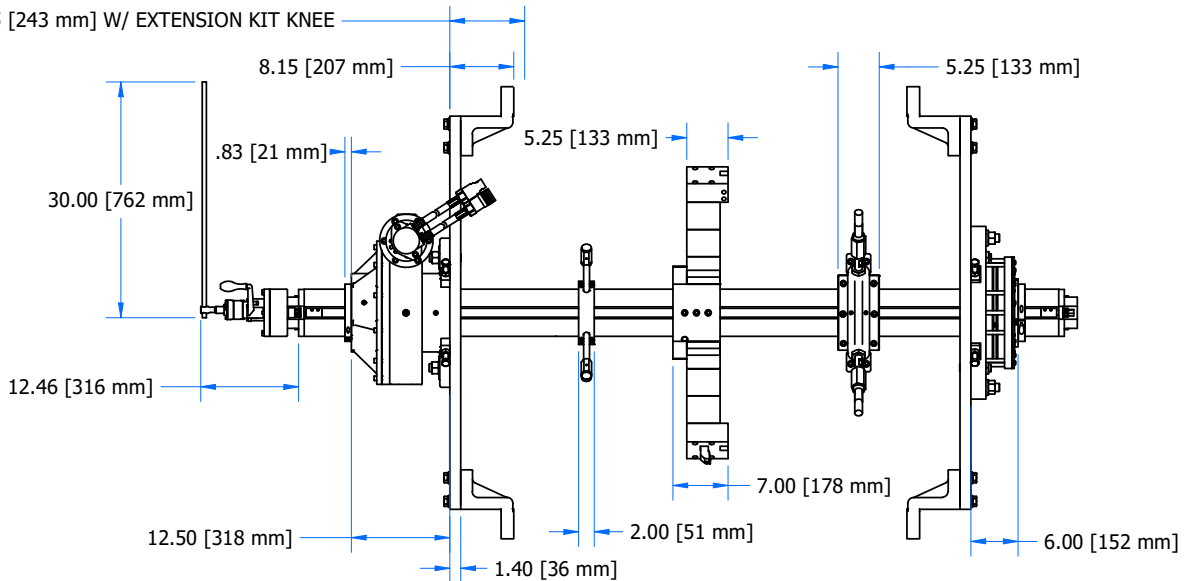

All dimensions and hydraulic requirements are for reference and may be subject to change without notice. Machine performance is subject to application and operator capability; please discuss your requirements directly with a Mactech sales representative. All information given and all sales made by Mactech Inc. are subject to their terms and conditions.