

624 FLANGE FACER

MACTECH PORTABLE MACHINING SOLUTIONS

Mactech's Newest Flange Facer

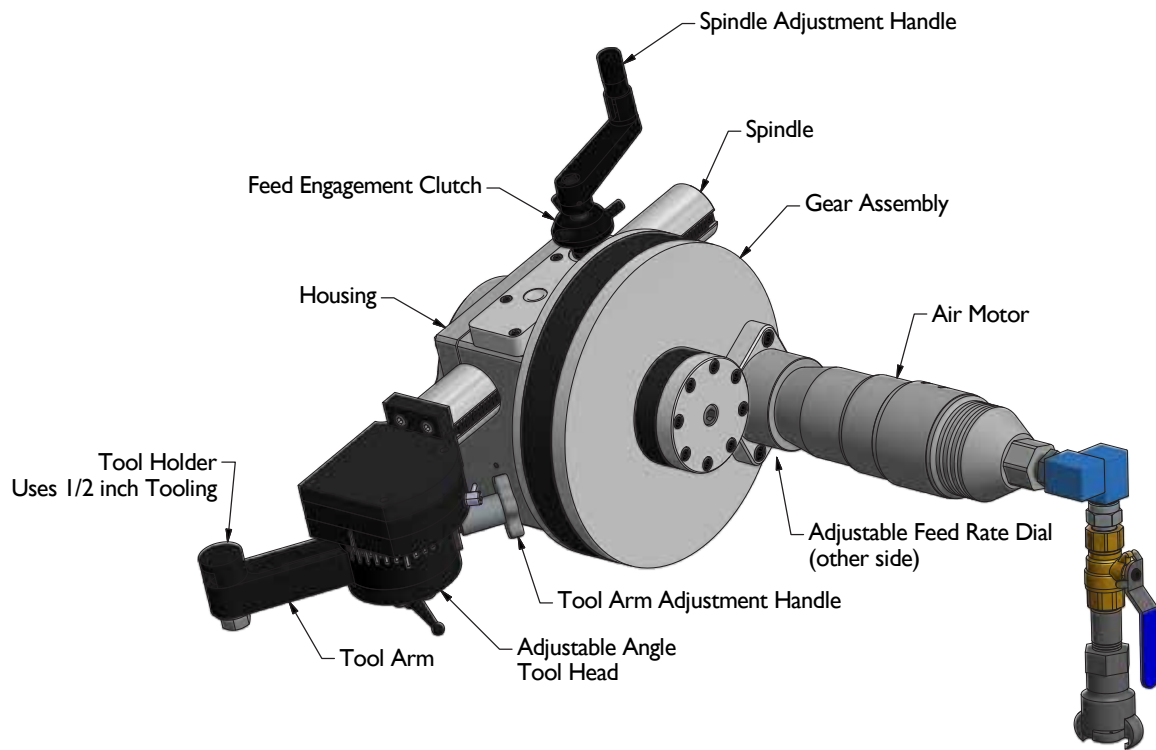

Mactech 624 Flange Facer

Mactech Introduces its Newest Flange Facer

Mactech's 624 Flange Facer is a lightweight, easy to set up facing and beveling machine. The two-piece system makes installation quick and easy. Simply install the mounting chuck into the bore, then attach the flange facer to the chuck. The chuck system makes centering and alignment quick and easy. Once the chuck is installed the flange facer can easily be removed, keeping the centering and alignment of the chuck in place. The adjustable angle tool holder provides both facing and beveling operations. The 624 Flange Facer is capable of machining phono-grooves and O-ring grooves. Only one operator is required for set up and operation.

Features

- Adjustable radial feed rate.
- Lightweight, Easy to set up.
- Facing and Beveling capabilities.
- Only one operator required for set up and operation.

Specifications

Facing Diameter Range: 6 to 24 inches
ID Mounting Diameter Range: 5 to 20 inches
Feed Rate (adjustable): 0 to .030 inches/revolution
Tooling: Uses standard 1/2 inch tool bits
Drive System: Air-powered drive
Weight: 64 lbs. (does not include chuck assembly)

MACTECH
ON-SITE MACHINING SOLUTIONS

Mactech, Inc. • 4079 Pepin Ave. • Red Wing, MN 55066
PH: 651-388-7117 • TOLL FREE: 800-328-1488 • FAX: 651-388-0337
www.mactechonsite.com