

# CLAMSHELL AXIAL FEED ACCESSORY

MACTECH PORTABLE MACHINING SOLUTIONS

## Extend the Versatility of your Clamshell Lathe!

**Mactech's Axial Feed Accessory** is an attachment for our popular and reliable Clamshell Portable Lathes. The Axial Feed Accessory is designed for machining along the length of round pipes, tubes or shafts. The optional backing plate adds rigidity and provides precise positioning on the workpiece. The Axial Feed Accessory is ideally suited for removing weld overlay and can also perform precise machining operations. The Axial Feed Accessory can be installed on all Mactech LC, US and USS Clamshell Lathes.

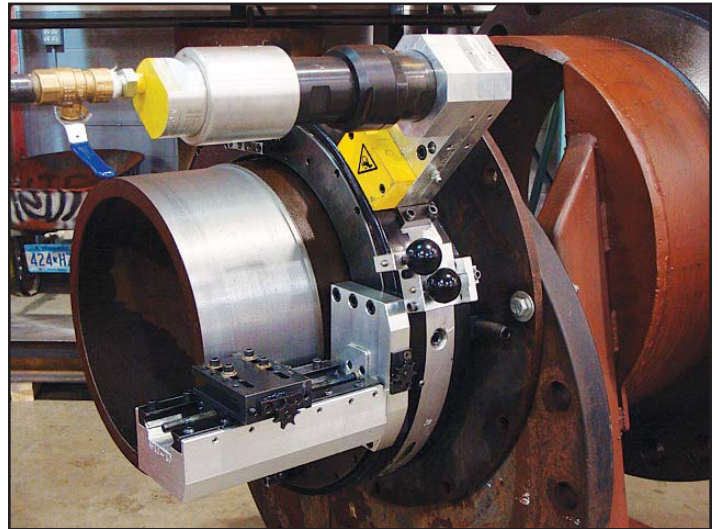

**814LC Clamshell with Axial Feed Accessory**

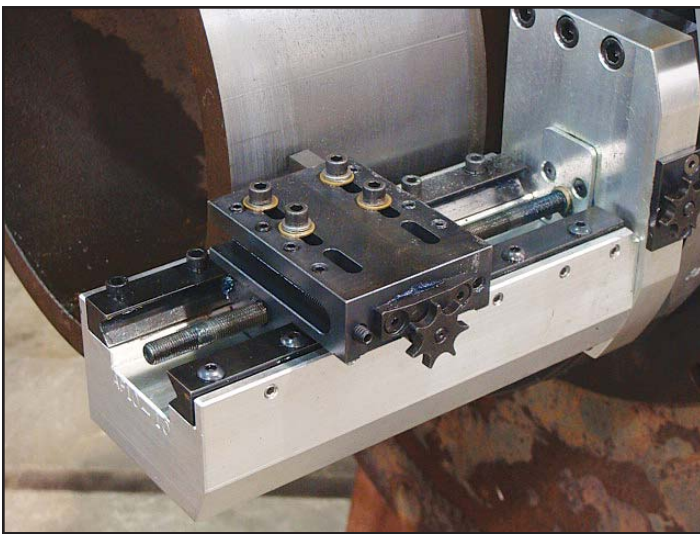

**Axial Feed Accessory Machining Pipe**

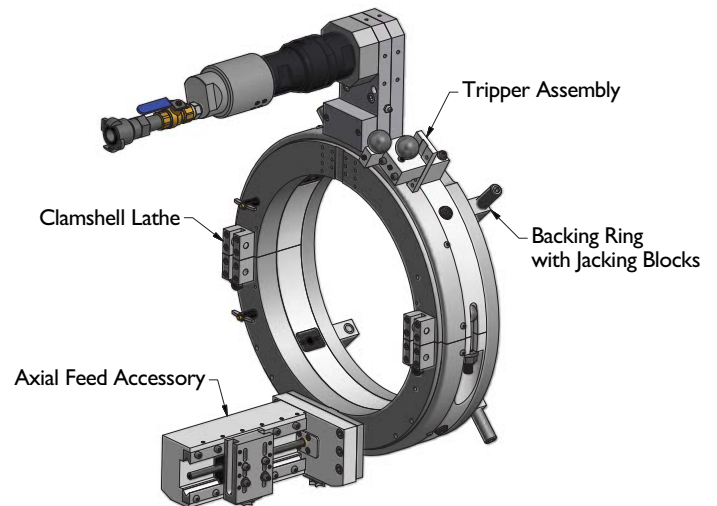

**Axial Feed Accessory and Backing Ring**

**Weight:** 18.2 lbs (8.3kg)

**Tooling:** Accepts standard 1/2 inch tooling  
(12.7mm)

**MACTECH**  
ON-SITE MACHINING SOLUTIONS

Mactech, Inc. • 4079 Pepin Ave. • Red Wing, MN 55066  
PH: 651-388-7117 • TOLL FREE: 800-328-1488 • FAX: 651-388-0337 • [www.mactechonsite.com](http://www.mactechonsite.com)

# CLAMSHELL AXIAL FEED ACCESSORY

MACTECH PORTABLE MACHINING SOLUTIONS

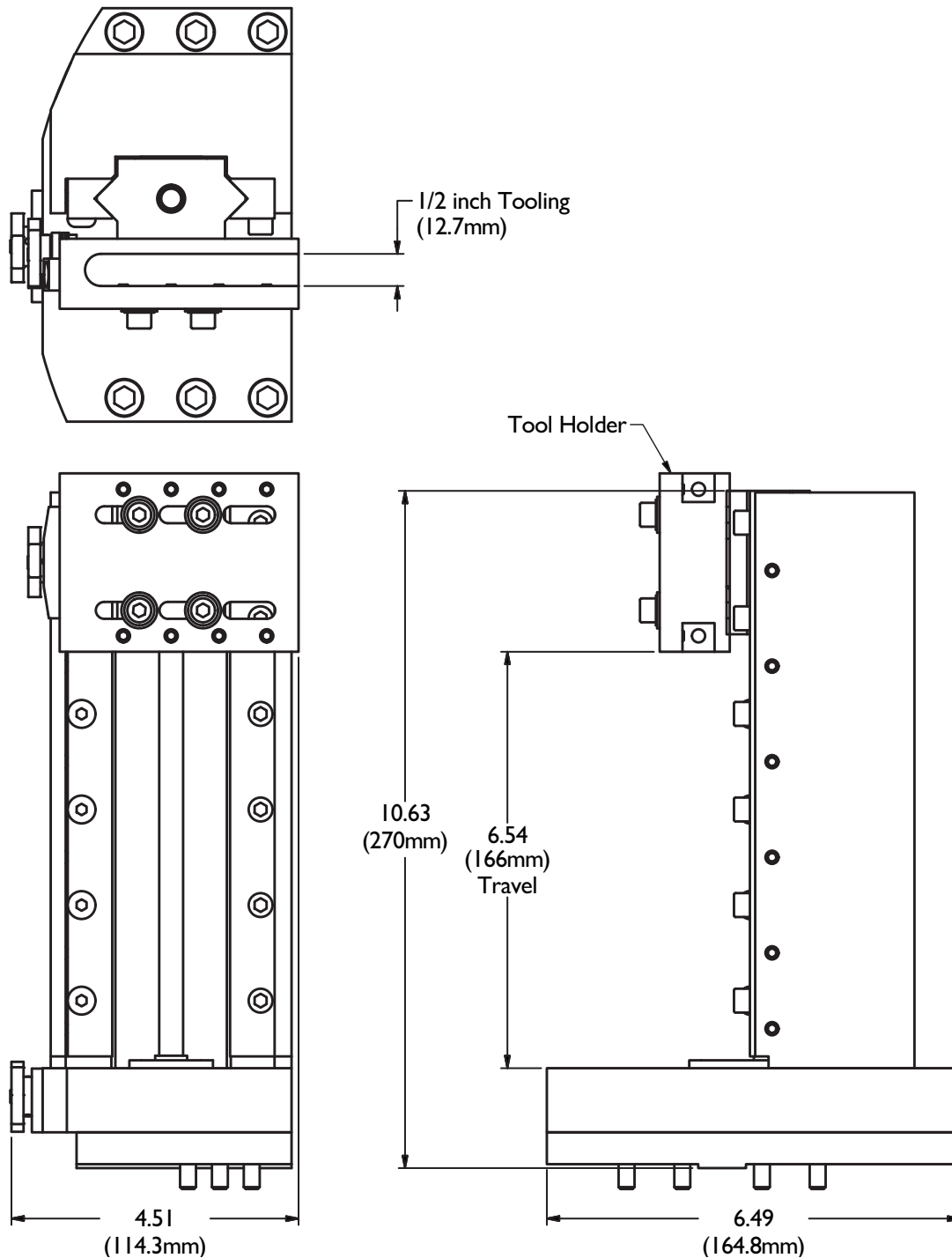

*Axial Feed Accessory Dimensions*

