

PORTABLE KEYWAY MILL

MACTECH PORTABLE MACHINING SOLUTIONS

Portable Keyway Cutting up to 14 Feet

Mactech Portable Keyway Mill

The Mactech Portable Keyway Mill is designed for accurate cutting of internal and external keyways along long length pipe or tube.

Features

- Cuts internal and external keyways
- Swiveling Mill Head Frame allows one setup for two keyway cuts.
- Small footprint for big jobs
- Powerful electric drive feed and hydraulic drive mill.
- Accurate long-length keyway cutting, quick and easy setup.

Specifications

Drive System

- **Drive Motor**

Continuous-duty DC Electric Gearmotor, UL and CSA approved.

Max Output: 1/2 hp (0.37 kw)

Speed at Max Output: 42 rpm

Torque: 705 in-lbs (79 N-m)

- **Spindle Motor**

Low-speed, High-Torque Geroter Hydraulic motor.

Displacement: 9.7 in³/rev (159 cc/rev)

Max Continuous Pressure: 1650 psi (114 bar)

Max Continuous Speed: 353 rpm

Max Continuous Torque: 2059 in-lbs (232 N-m)

Max Continuous Flow: 15 gpm (57 lpm)



Portable Keyway Mill

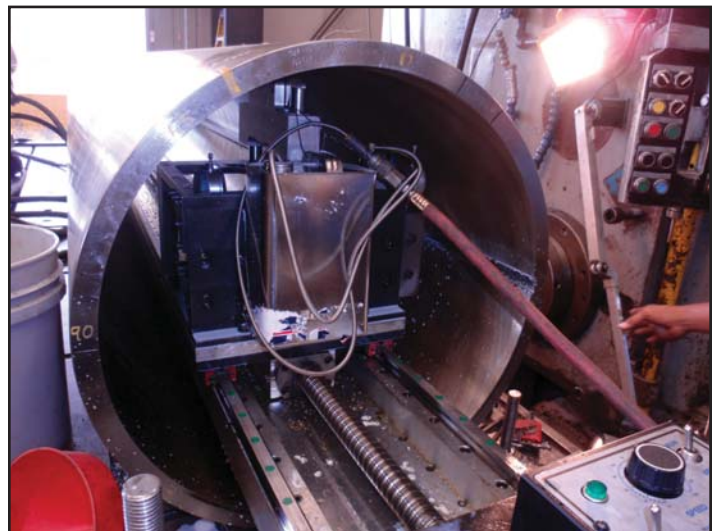

Keyway Cutting Long Tube

Feed Rate: 0 to 21 inches/minute
(0 to 533.4mm/minute)

Operating Weight: 1036 lbs (470 kg)

MACTECH
ON-SITE MACHINING SOLUTIONS

PORTABLE KEYWAY MILL

MACTECH PORTABLE MACHINING SOLUTIONS

Keyway Mill Dimensions

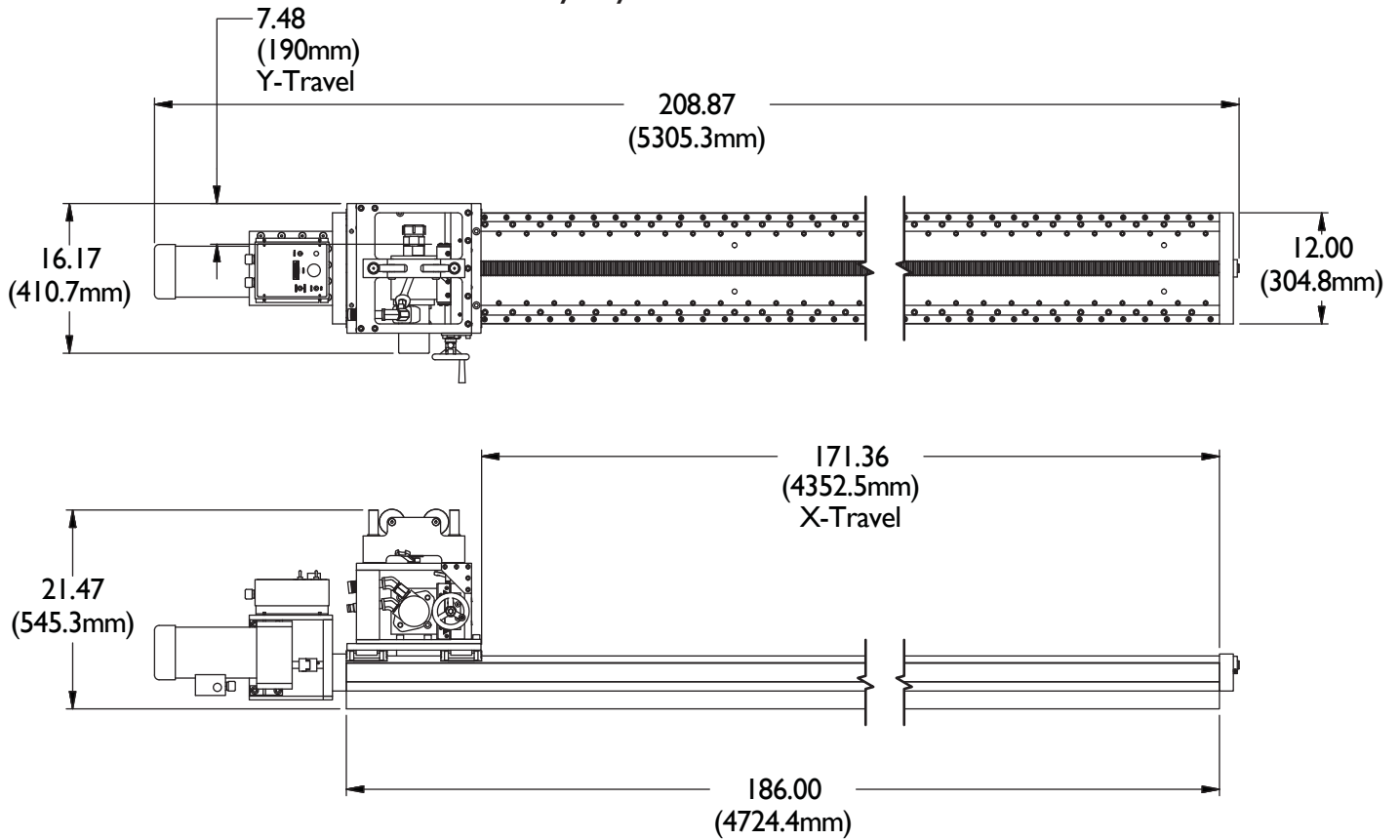

Components

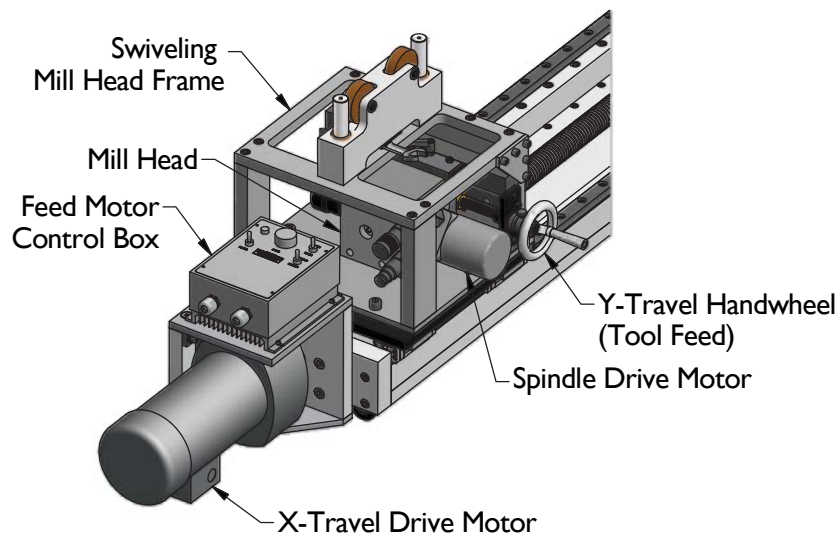

MACTECH
ON-SITE MACHINING SOLUTIONS