

# SHAFT TURNING DATA SHEET

Complete this form and return to Mactech, Inc.  
 Attach all blueprints and supporting documentation to this sheet.



Given By: \_\_\_\_\_ Date: \_\_\_\_\_ Plant: \_\_\_\_\_

Checked By: \_\_\_\_\_ Date: \_\_\_\_\_ Work Order No.: \_\_\_\_\_

Site Contact: \_\_\_\_\_ Site Contact No.: \_\_\_\_\_

SHAFT DATA			
Coupling Area Diameter (SC)		Thread Size (TS)	
Coupling Area Length (CL)		Center Hole Size (CHS)	
Bearing Area Diameter (BD)		Material Removal	
Bearing Area Length (BL)		Material Type	
Seal Area Diameter (SD)		Sleeve Required on which area?	
Seal Area Length (SL)		Clearance from end of shaft	
Bolt Circle (BC)		Clearance around shaft	
Number of Holes		Machine Position	

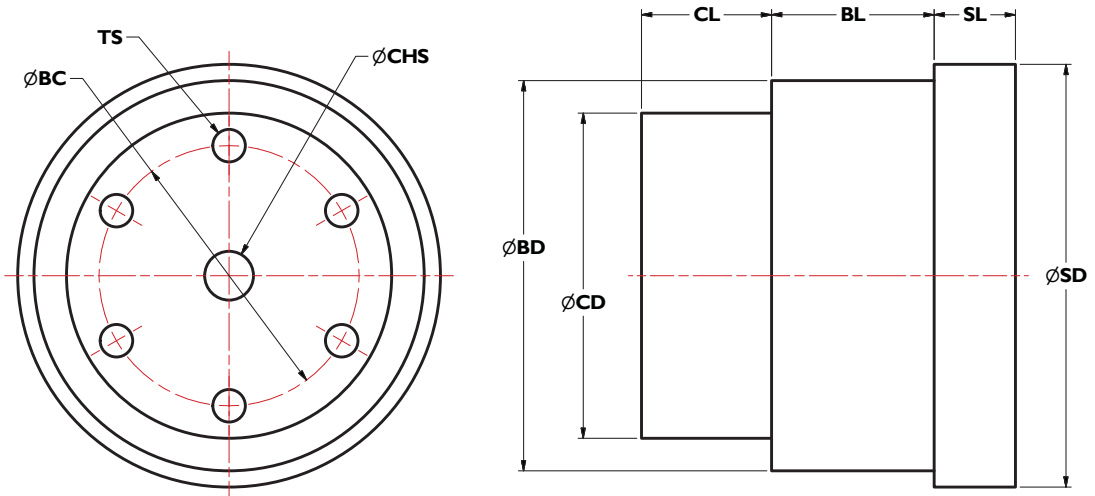

## Special Instructions:

---



---



---

## Customer Field Representative Acknowledgement

Signature: \_\_\_\_\_ Date: \_\_\_\_\_

