

STRESSTECH TWIN ZONE 600

OPERATING INSTRUCTIONS AND PARTS LIST

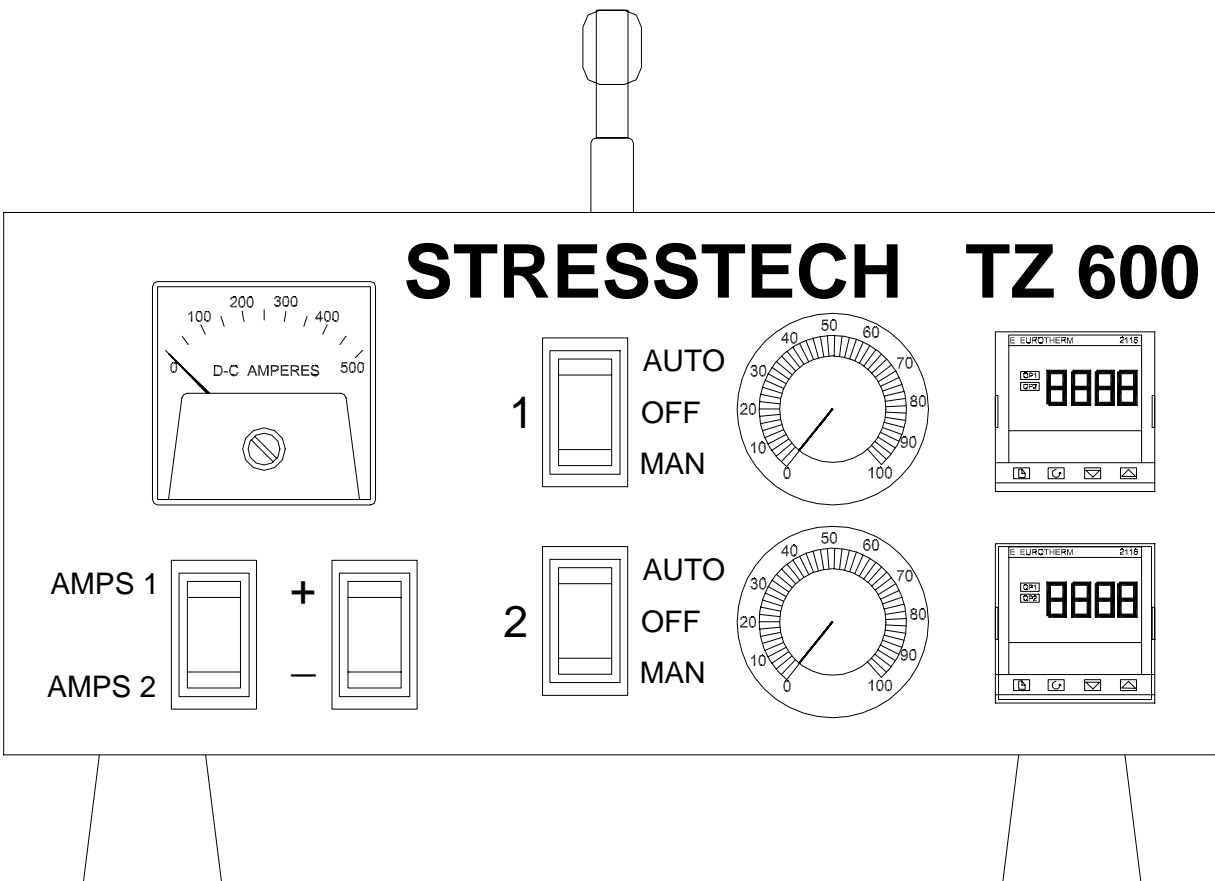

Table of Contents

General Information	1
Post Weld Heat Treatment Set-up	2-4
Top Temperature Controller	5
Operating Instructions	6-9
Trouble Shooting	10-11
Service and Maintenance	12
Parts List	13-16
Wiring Diagram	17

Electrical Specifications:

Rated Control Input	120 VAC 5 AMPS 1 PHASE 60 HERTZ
Current Capacity (per zone)	300 AMPS DC 80 VOLTS DC
Rated Duty Cycle	Continuous - 100%

Physical Dimensions:

Height:	8.5"
Width:	14.5"
Length:	16.5"
Weight:	30 lbs.

General Information:

The STRESSTECH TWIN ZONE 600 is a two zone temperature controller which can be operated semi-automatically (auto-ramping up and down, hold at temperature), or manually (manual ramping, no hold temperature). It consists of two 300 amp contactors, 0-2000 deg. F. temperature controllers, percentage timers for controlling the rate of heating and cooling, if desired. The TZ 600 also has a 0-500 DC ammeter, with polarity selection, to aid in monitoring the current supplied to the heating elements being used. (Each element will use approximately 50 amps @ 80 DC volts.)

The top temperature controller will maintain any selected temperature between ambient and 2000 deg. for as long a period of time required. The controller will control the heating and cooling rate by opening or closing the contactor as needed.

The contactor, normally open, will close providing current to the heating elements up to a maximum of 300 amps, at 80 DC volts.

Post Weld Heat Treatment Set-up:

1. Prepare thermocouple wire for attachment to work piece:
 - a) Cut two thermocouple wires 24" or longer (thermocouple wires should extend beyond insulation).
 - b) Strip insulation back approximately 1/4" - 3/8" on both ends of each wire.
 - c) On one end of each wire, trim lead ends to a fine point and bend the last 1/8" at a 90 degree angle.
 - d) On the opposite end of one wire, install a male thermocouple plug. Yellow wire (+), Red wire (K).
 - e) Lightly twist the two wires together. The wire without the plug will be a spare.

2. Attach the prepared thermocouple wires onto the work piece using the capacitor-discharge spot welder (ZAP GUN). Operating instructions, for attachment of thermocouple wires, are on the inside of the Zapgun lid.

3. Thermocouples shall be attached in the following minimum location(s):

ON A HORIZONTAL WORK PIECE:
 - a) Always at the bottom-dead-center.
 - b) For component diameters 12 inches or more, add a second thermocouple at the top-dead-center.
 - c) For component diameters over 24 inches, place thermocouples at each 90 degree intermediate location.
ON A VERTICAL WORK PIECE:
 - a) The same number of thermocouples as above shall be attached, spaced evenly.

4. Thermocouples shall be attached in each zone where heaters are separately controlled.

5. Thermocouples should be placed so that the anticipated coolest and hottest areas within the heating band are monitored.

Post Weld Heat Treatment Set-up Cont:

6. When the component wall thickness adjacent to the wall vary significantly (such as by the thicker side being more than about 25% or 1/2" greater than the thinner) then:

- a) Additional thermocouples shall be attached so that each of the above required locations have thermocouples close to the weld, but both on the thin and thick materials that will be under the heating band (e.g., for a pipe welded to a heavy valve) and,
- b) for even larger thickness differences (such as for a pipe to a very heavy vessel nozzle), even more thermocouples should be attached on the thicker material, at a distance from the weld equal to about 3 times the wall thickness at the weld. If such thermocouples are beyond the heating band, the gradient should be controlled if and as required by the Specific Project Instructions.

7. A system shall be established for positive identification of each thermocouple with the location on the work piece. A sketch or written description of thermocouple locations should be made, identifying each thermocouple.

8. Select the heating element(s) that best cover the area to be heat treated.

9. Tape the heating element(s) onto the work piece using fiberglass strapping tape, and then use stainless steel banding to fasten them securely.

10. Insulation shall completely cover the heating elements, and extend beyond their edges somewhat. If possible, the insulation should be at least twice as wide as the heating band.

11. Fasten the insulation securely to the work piece by using tie wire or banding.

12. Heating element tails should be brought directly out of the insulation, so as not to overheat the connectors.

13. Connect thermocouple(s), using thermocouple extension leads, to the thermocouple jack strip on control unit. MAKE SURE thermocouples are plugged into proper jacks; i.e., thermocouple #1 on work piece must be connected to thermocouple jack #1, etc.

Post Weld Heat Treatment Set-up Cont:

14. Connect heating elements to splitter cables: (figure 1)

- a) Heating elements associated with thermocouple zone #1, must be connected to circuit #1. This sequence follows through for each zone of control.
- b) Connect a tail from each heating element in circuit #1, to a splitter cable.
- c) Connect the other tail from each heating element in circuit #1, to a different splitter cable.
- d) Using 2/0 power cable extension leads, connect the two splitter cables from circuit #1 to the two corresponding jacks on the control unit.
- e) Repeat steps b-d, if connecting more than one zone of control.

15. Using 6 ft. male to male thermocouple jumper wires, you can connect a temperature recorder to the thermocouple jack strip on the control unit.

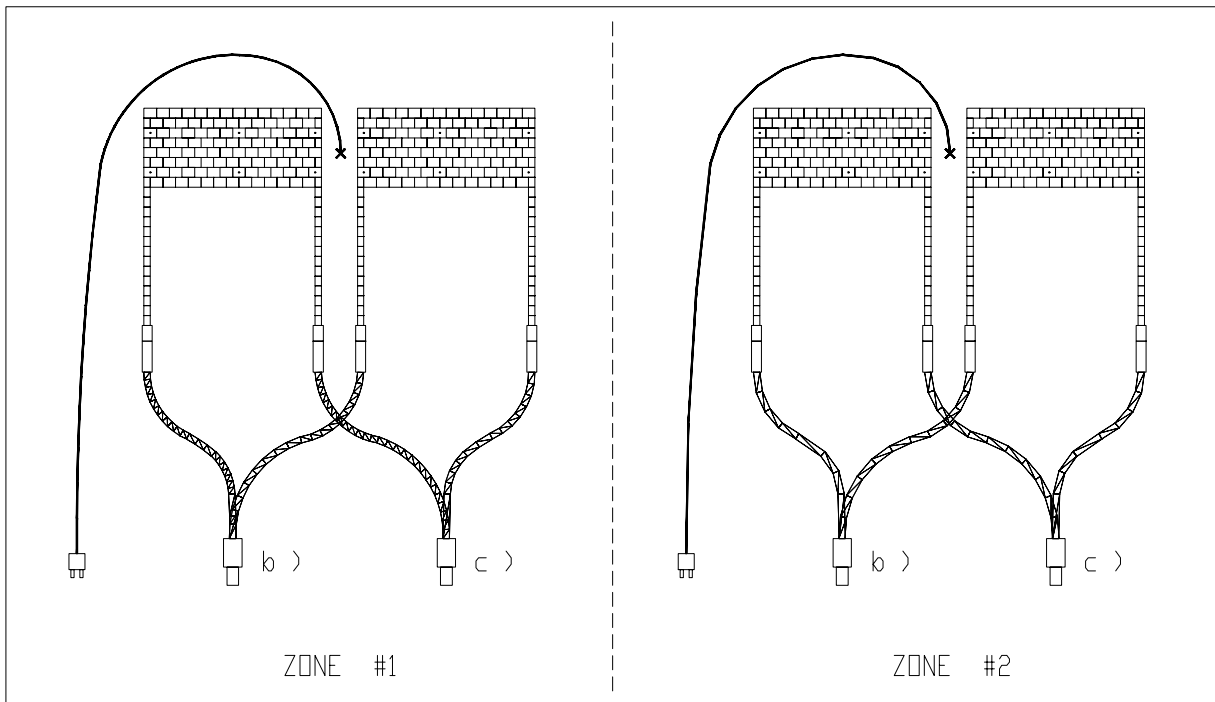





(figure 1)

TOP TEMPERATURE CONTROLLER

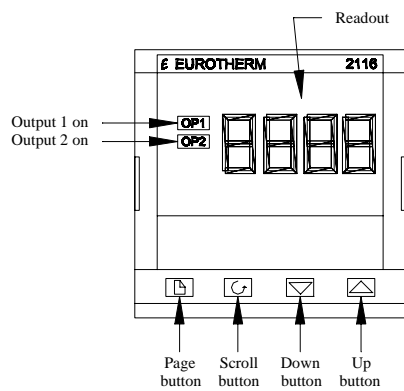
KEY FUNCTIONS AND DISPLAYS:

FRONT PANEL LAYOUT



INDICATOR OR BUTTON	NAME	FUNCTION
OP1	OUTPUT 1	When lit, this indicates that the logic output is on.
OP2	OUTPUT 2	When lit, this indicates that the relay output is on.
	PAGE BUTTON	Press to select a new list of parameters.
	SCROLL BUTTON	Press to select a new parameter in a list.
	DOWN BUTTON	Press and release to view the setpoint or a selected parameter. Keep pressed to decrease the value.
	UP BUTTON	Press and release to view the setpoint or a selected parameter. Keep pressed to increase the value.

Operating Instructions:

1. Be sure the auto/manual switches on the TZ 600 are in the OFF position.
2. Insure power is off on your 80 vdc power supply.
3. Connection of 80 vdc power leads: (figure 2)

ZONE #1

- a) Connect the positive lead from the power supply to the male cam-loc on the rear of the TZ 600, marked "IN".
 - b) Connect a lead from the heating elements to the female cam-loc on the rear of the cabinet marked "OUT".
 - c) To complete the circuit, connect the remaining lead from the heating elements to the negative post on your power supply.
4. Insert the thermocouple lead, from the work piece, into one of the (#1) thermocouple jacks on the rear of the TZ. The second (#1) jack is used for connecting a temperature recorder.(figure 2)
 5. Repeat steps 3 and 4 using Zone #2 if heating a second area.

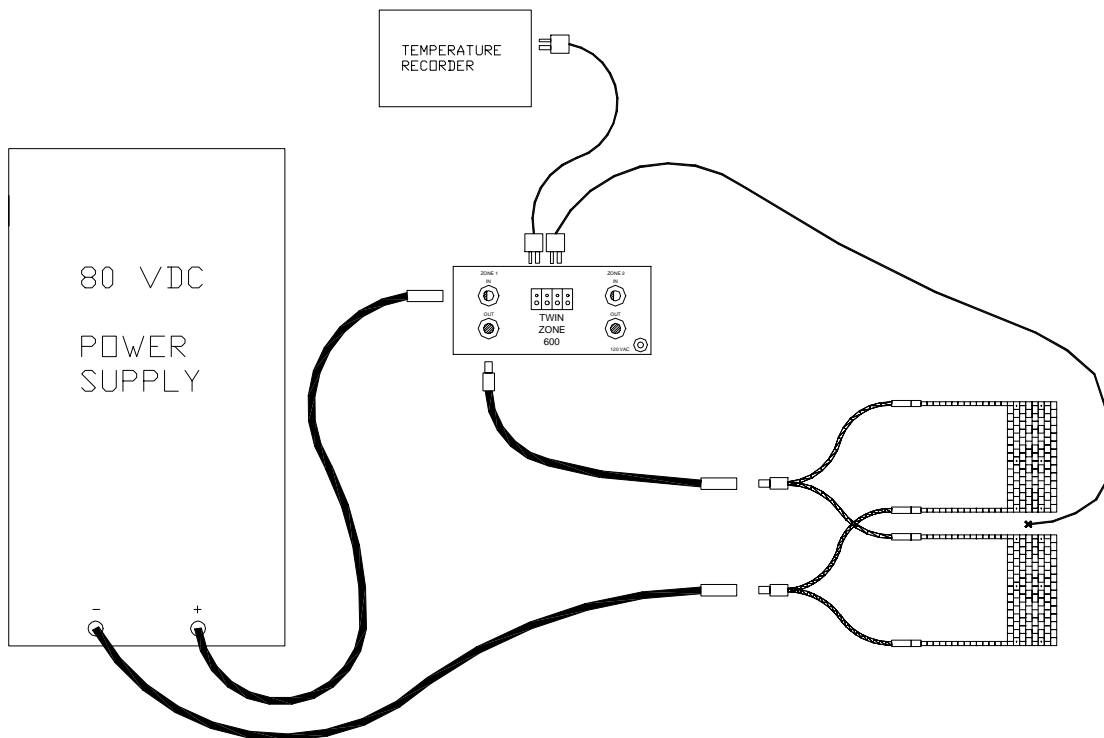

(figure #2)

Operating Instructions Cont:

AUTO OPERATION

6. Plug the TZ 600 power cord into a 120 vac source.
7. Do not turn on the 80 volt power supply until you finish programming the controller.
8. Push the auto/manual switch to the auto position.
9. Set the top temperature controller to the desired holding temperature (set value):
 - a) The controller runs through a self test for about three seconds and then displays the measured value. This is called the HOME display.
 - b) To view the set value, press and release the UP or DOWN key. The set value will be shown for approximately 2 seconds.
 - c) To change the set value, press the UP or DOWN key until the desired soak temperature is displayed. After two seconds the new value will be accepted and the controller will return to the HOME display.
10. Set the top temperature controller to the desired heating ramp rate:
 - a) Press the SCROLL key twice and an indication of "SPrr" (set point ramp rate) appears.
 - b) To view the ramp rate value, press the UP or DOWN key. The value shown is in degrees per minute. After two seconds the display will return to "SPrr".

For example,
If you wish to enter a ramp rate of 300 degrees/hour,
you perform the following calculation:
300 degrees/hour divided by 60 minutes = 5 degrees/minute.

 - c) Change the data indication to the desired ramp rate, using the up and down-keys.
 - d) The display will return to "SPrr" after two seconds.
 - e) After 45 seconds the controller will return to the HOME display. Or you can press the PAGE or SCROLL key once to return to the HOME display.

Operating Instructions Cont:

11. Once you have the desired set value, and ramp rate entered into the controller, push the auto/manual switch to the off position.
12. Turn the percentage timer to 100%.
13. Turn the 80 vdc power supply on.
14. Turn the temperature recorder on to record mode.
15. Push the auto/manual switch to the auto position. This enables the unit to use both the top temperature controller and the percentage timer. In the manual position only the percentage timer is used, the top temperature controller does not effect the output.
16. The controller will ramp from the present temperature, at the rate you entered into the "SPrr" parameter, to the soak temperature you entered for the set value.
17. While the controller is ramping, the display may flash "ldLo".
Which is a low deviation alarm, to let you know the workpiece is not keeping up with the controller.
18. The display may also flash "2dHi". Which is a high deviation alarm to let you know the workpiece is not keeping up.
19. The controller will hold the workpiece temperature at the set value until you change it to a new value.
20. At the end of the soak time you will need to change the set point ramp rate "SPrr", if the cooling rate is different than the heating rate. If the rates are the same you won't have to change it.
21. Once the correct cooling rate is entered into the "SPrr", you will need to change the set value to 0 degrees.
22. The controller will now ramp from the soak temperature down to 0 degrees.

Operating Instructions Cont:

23. The weldment area shall be first brought up to about 200 degrees. The temperature recorder shall be checked then for temperature readings of each thermocouple, and for correct chart speed.

24. During the PWHT cycle, the current should be occasionally checked, especially if any abnormal temperature readings are obtained. A significant drop, such as by the rating of one heater (about 50 amps), would indicate that a heater may be burned out.

25. At no time shall any two thermocouples, within the heating band, be allowed to differ by more than 150 degrees. If this temperature difference is approached during heating, the heating rate should be slowed.

26. Heating shall continue until reaching the holding temperature required by the applicable Welding Procedure.

27. At the completion of the holding time, begin the cooling.

28. The power shall not be completely shut off until the temperature cools down to below 600 degrees, unless it is determined by continuous monitoring that the maximum cooling rate will not be exceeded, or that the temperature difference between any two thermocouples will not differ by more than 150 degrees.

29. Insulation coverings shall not be removed until the temperature drops below 200 degrees, although any stuffed in the ends to fill gaps may be removed if the work piece is in still air and will not exceed the maximum allowable cooling rate.

30. Check all equipment for damage or wear. Any damaged equipment should be repaired immediately or replaced.

Trouble Shooting:

1. Temperature does not increase on controller:
 - a) Be sure the 80 vdc power supply is on.
 - b) Percentage timer is turned up to 100%.
 - c) Check for correct connections of the cables.
 - d) Check the ammeter on the front of the unit.
(each heating element draws approximately 50 amps)
 - e) Check the set value and set point ramp rate "SPrr" settings on the controller.
2. Temperature does not increase on recorder:
 - a) Check male to male thermocouple wire for a bad connection at one of the plugs.
3. Temperature decreases on recorder or controller:
 - a) The thermocouple wires have been reversed in one of the plugs. The yellow wire should be in the positive (+) slot and the red wire in the negative (-) slot.
4. Contactor chatters:
 - a) Check the thermocouple connections first. If all the connections are ok, the contactor may be worn out.
5. Temperature swings when holding at a set point with the top temperature controller:
 - a) Thermocouples are located too far from heating elements. The swing can be reduced by turning the percentage timer down, if the full power is not needed to maintain the temperature.
6. Temperature does not stop rising after reaching the set value:
 - a) Be sure the auto/manual switch is in the auto position.

Trouble Shooting Cont:

7. Fault indication on top temperature controller:

- a) The controller has a fault indicating function so that the cause of fault can be removed quickly. These warn that a fault exists in either the controller or the connected devices.

INDICATION	:	WHAT IT MEANS
1dLo	:	Deviation low alarm
2dHi	:	Deviation high alarm
S.br	:	Thermocouple sensor break
LLLL	:	Out of range low reading
HHHH	:	Out of range high reading
EE.Er	:	
Err1	:	
Err2	:	Return for repair
Err3	:	
Err4	:	

REPAIR AND CALIBRATION

Due to the nature of its design, if a controller fails to operate correctly consult STRESSTECH. Special equipment is required for calibration and unit MAY have to be returned for repair.

Service And Maintenance:

NEVER work on a unit unless primary power has been disconnected or locked out.

1. Keep control unit clean and dry.
2. Periodically check all thermocouple wires and power cables for loose connections or damage. Any damage should be repaired immediately or replaced.
3. Every six months remove the cover from the unit and, using clean dry air, blow out all dust and dirt from the inside. Do not exceed 25 psi.
4. Keep cam-lok connectors clean using scotchbrite pads.
5. Contactor maintenance:
 - a) The main contacts should be given regular attention, especially where heavy loads are involved or a high number of operations per hour.
 - b) These contacts are plated with silver cadmium oxide giving it the same corrosion protection as pure silver, but greater resistance against contact welding.
 - c) Contact surfaces should not be polished or greased.
 - d) Worn-off contact dust should be carefully brushed off the insulating parts at each inspection. The de-ionizing laminations of the arc shield are made of steel plate to which beads of fused metal may stick so that the laminations become electrically connected. If this has occurred, the beads must be removed by means of a smooth file or suchlike. If there are layers of sintered contact dust on the inside of the arc shield, these should also be scraped off.
 - e) Change all three contact points if any one becomes badly worn or pitted.

For further information or parts contact STRESSTECH,
Clay City Industrial Park, Red Wing, Minnesota 55066;
or call toll free 1-800-328-1488.

(figure A)

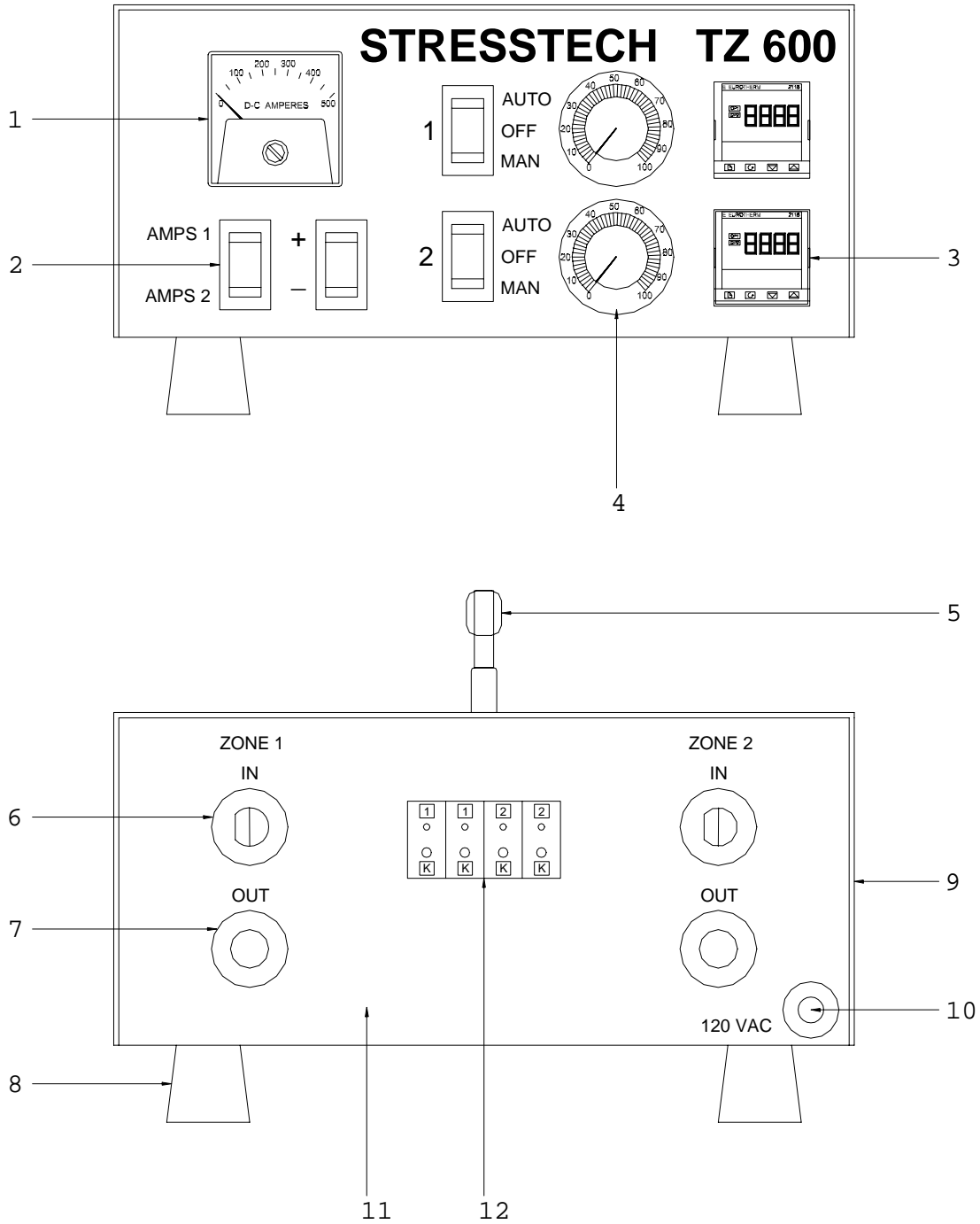

Parts List (figure A):

1.	Ammeter (0-500amp)	12005721
2.	Auto/Manual Switch (4)	12008410
3.	Top Temperature Controller (2) Eurotherm 2116 Controller	12008645
4.	Aluminum Knob Dial Plate	12009959 12009995
5.	Stresstech Handle	12004510
6.	Male Cam-lok - Power In (2)	12002150
7.	Female Cam-lok - Power Out (2)	12002160
8.	Rubber Feet (4)	12007410
9.	Twin Zone 600 Cover	12002032
10.	120 VAC Power Cord Power Cord Connector	12007030 12007035
11.	Twin Zone 600 Cabinet	12002041
12.	Thermocouple Strip	12008904

(figure B)

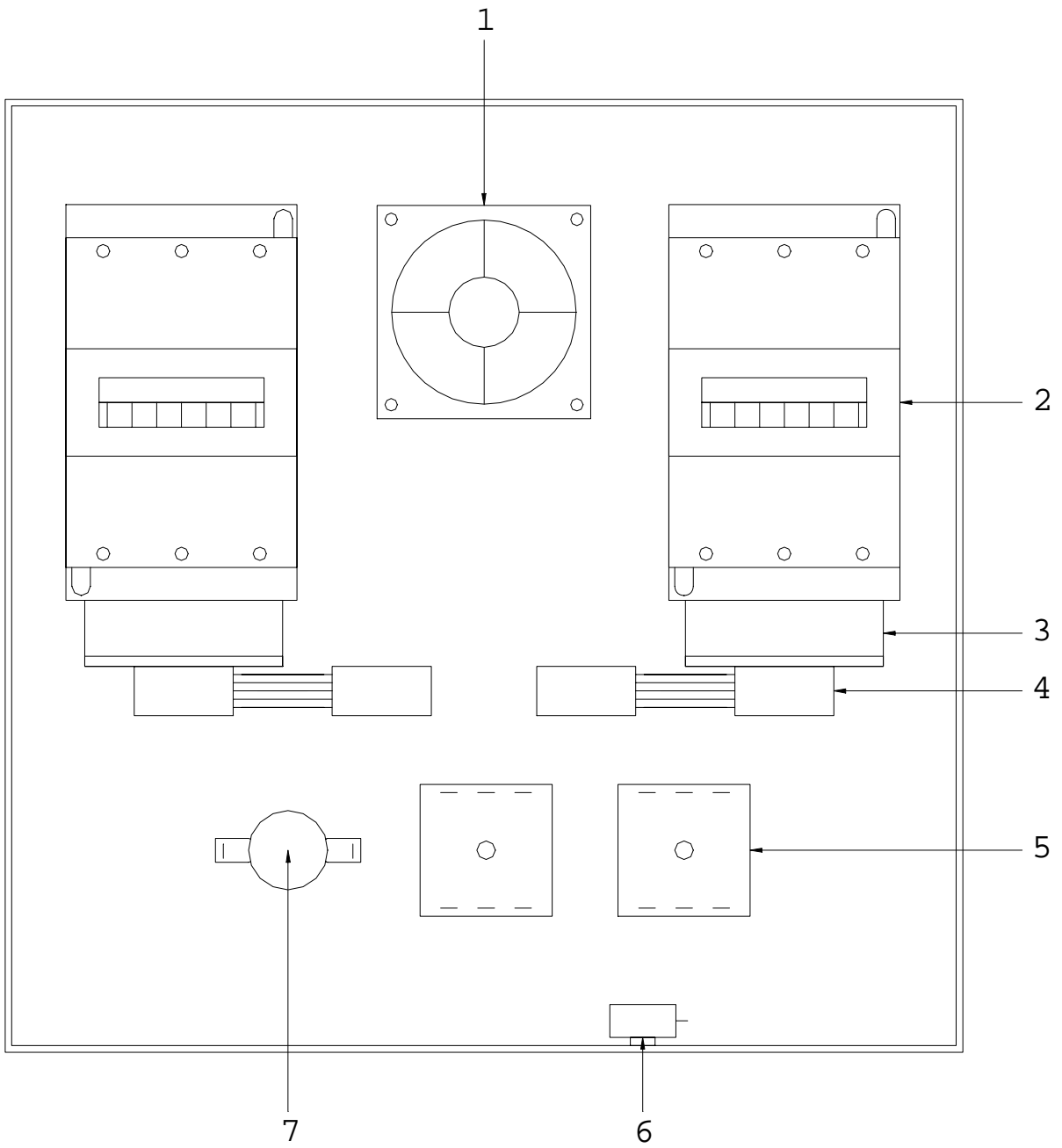

Parts List (figure 2):

1.	Cooling Fan	12002225
2.	Zone Contactor (2)	12002760
3.	Contactor Bussbar (4)	12001928
4.	500 Amp DC Shunt (2)	12007820
5.	Solid State Timer (2)	12006702
6.	Timer Adjusting Pot. (2)	12009984
7.	Thermostat	12008471

TWIN ZONE 600 WIRING DIAGRAM

